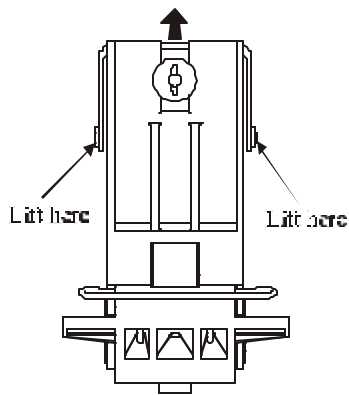
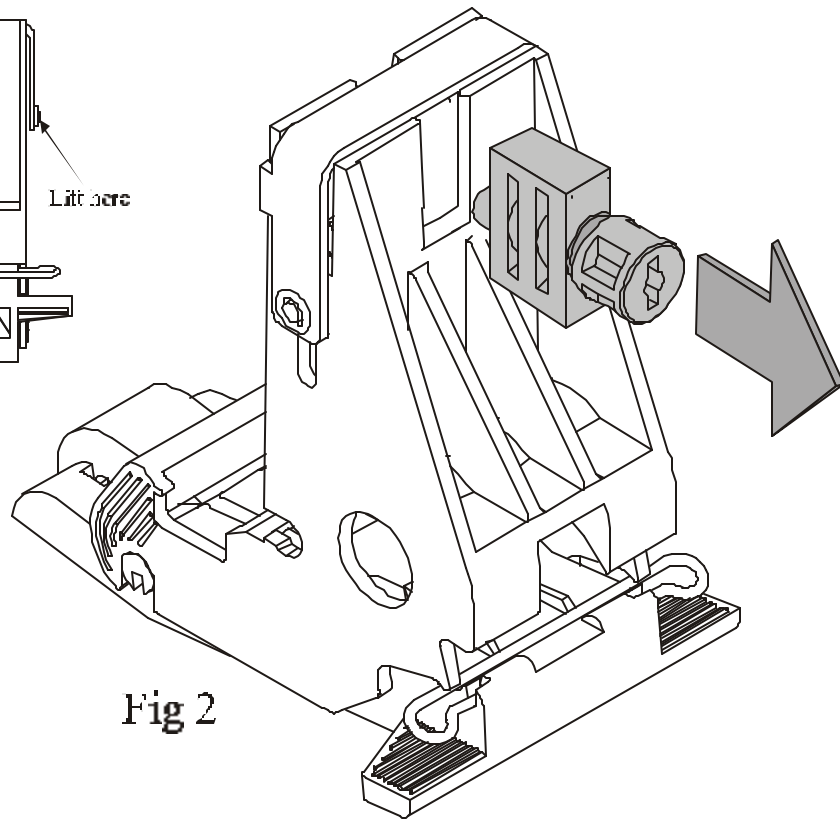

This procedure requires 2 people positioned at the front and rear of the SmarTrac Signcutter.

1. From the rear of the machine rotate the force adjustment cam slot to the vertical position with a flat head screwdriver (24-lb. setting).
2. From the front of the machine have your assistant reach over the top cover and lift the spring-loaded bracket at the points illustrated in *Fig 1*.
3. Remove the cam by pulling it straight out of the square hole as illustrated in *Fig 2* (rotate if necessary).
4. Insert the new cam.
5. Your assistant can then release the spring-loaded bracket.

**Fig 1****Fig 2**