

SERVICE BULLETIN FOR THE SMARTRAC CUTTER

Replacement of the cutting strip

1. Start by removing the old cutting strip. Use a pair of needle-nose pliers to grab one end of the strip, and pull it out of the body of the machine.
2. Once the cutting strip is out of the machine, the sticky tape under it needs to be removed. Remove as much as possible to make the channel flat. The glue can cause small variations in the cutting strip height if a new tape layer is placed over the old one.
3. Place a layer of double sided tape (roll) in the channel, and cut off the excess. When the tape is fully pressed down, remove the top backing material exposing the sticky tape underneath.
4. Place one end of the rubber cutting strip in the channel on the left side of the machine (Do not cut the strip to fit yet).
5. With your fingers, press the cutting strip into place in the channel moving across the machine as you go (*See drawing below*). Make sure the cutting strip sets down in the channel, and is flush with the body of the machine.
6. When you reach the right side of the machine, use a sharp "Exacto" knife to cut off the excess cutting strip.
7. Go over the cutting strip again making sure the whole strip is flush with the body of the machine. If there are any bumps, or the strip is raised in certain areas, you can use a hard smooth object to flatten it.

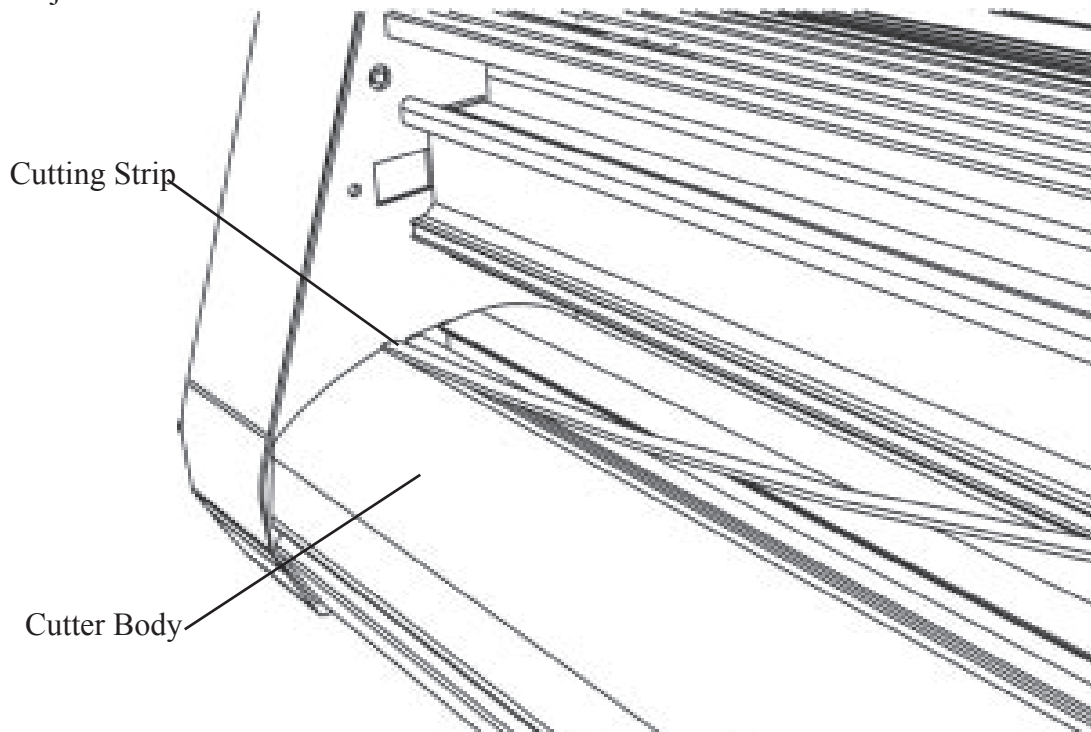

Installing the new cutting strip